

TAD 1631 GE

Genset Engine – Gen Pac

TAD 1631 GE

- Turbocharged
- Air to air intercooled
- Diesel fuel
- Displacement indication (l)
- Generation
- Version
- Generator Drive
- Emission Controlled

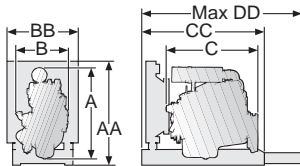

mm/in. AA = 1764/69.4
 A* = 1665/65.6 BB = 1261/49.6
 B* = 1261/49.6 CC = 2292/90.2
 C* = 2132/83.9 DD = 3730/146.9
 * Incl. radiator and intercooler

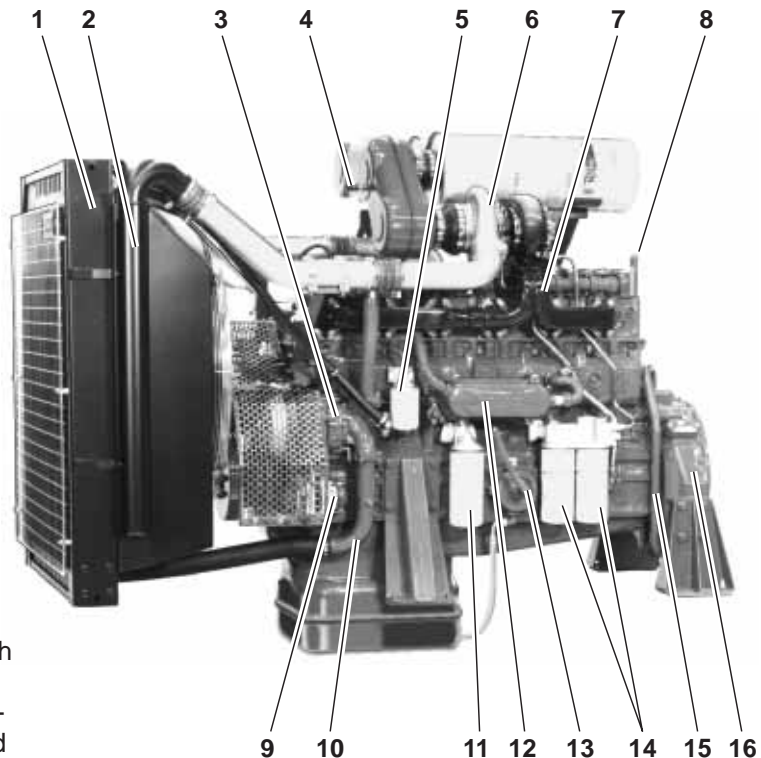

TT099

Gen Pac – Genset Engine mounted on an expandable base frame. Complete unit with engine, radiator, radiator core guard, fan, fan and belt guard providing reduced delivery time and installation cost and simplified transportation.

1. Tropical radiator
2. Intercooler
3. Gear-driven coolant pump
4. Air restriction indicator
5. Coolant filter
6. Turbocharger
7. Air cooled exhaust manifold
8. Lift eyelet
9. Alternator
10. Coolant pipe, inlet
11. By-pass oil filter of spin-on type
12. Oil cooler
13. Oil drain pump (optional)
14. Full-flow oil filters of spin-on type
15. Crankcase ventilation
16. Flywheel housing SAE 1
17. Relay for inlet manifold heater
18. Cable iron
19. Air filter
20. Inlet manifold heater
21. Twin fuel filters
22. Coolant pipe, outlet
23. Fan guard
24. Radiator guard (standard on Gen Pac)
25. Starter motor
26. Electronic speed governor
27. Fuel pipes for tank connection
28. Injection pump
29. Oil filler
30. Belt guard (standard on Gen Pac)
31. Automatic belt tensioner
32. Expandable base frame

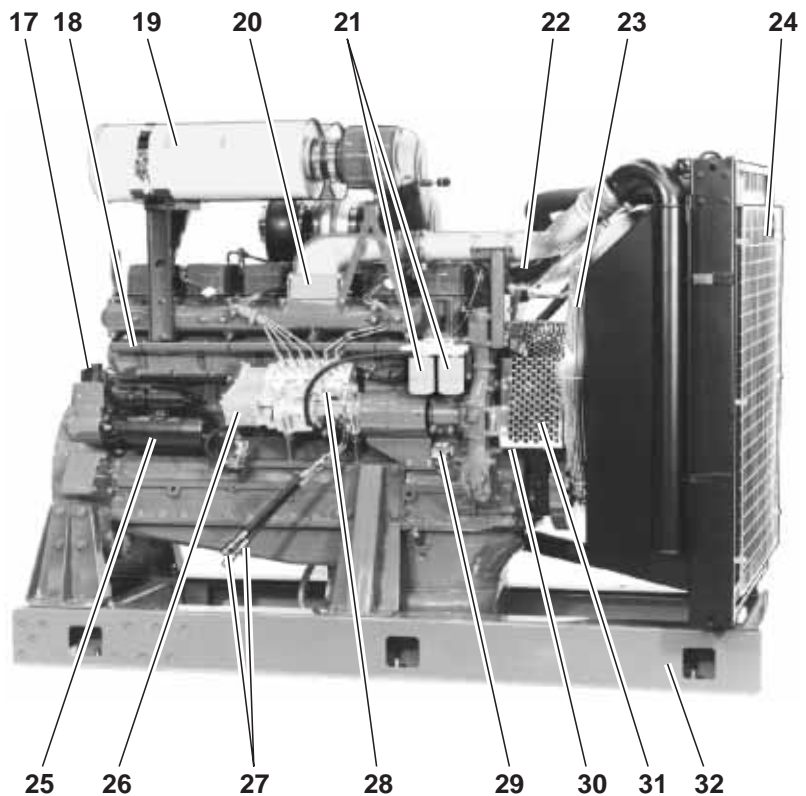

TT100

Technical data TAD 1631 GE

Volvo Penta reserves the right to make changes at any time, without notice, as to technical data, prices, materials, standard equipment, specifications and models, and to discontinue models.

General

In-line four-stroke diesel engine with direct injection		Bore		144.00 mm / 5.67 in	
Turbocharged and air to air intercooled		Stroke		165 mm / 6.50 in	
Number of cylinders	6	Compression ratio		15.0:1	
Displacement, total	16.12 liters / 984 in ³	Dry weight, kg/lb	Gen Pac	1795/3954	Engine only 1538/3388 *
Firing order	1-5-3-6-2-4	Wet weight, kg/lb	Gen Pac	1912/4212	Engine only 1650/3635 *
Rotation direction, anti-clockwise viewed towards flywheel		*) Including radiator and intercooler			

TAD 1631 GE	Speed, rpm	1500	1800
Performance	Test no.	21000065	21000063
Prime Power with fan	kW / hp	430 / 585	484 / 658
Continuous Standby Power with fan	kW / hp	430 / 585	484 / 658
Maximum Standby Power with fan	kW / hp	473 / 643	537 / 730
Mean piston speed	m/s / ft/sec	8.3 / 27.2	9.9 / 32.5
Effective mean pressure at Prime Power	MPa / psi	2.2 / 319	2.1 / 305
Max combustion pressure at Prime Power	MPa / psi	14.4 / 2089	15.2 / 2205
Total mass moment of inertia, J (mR2)	kgm ² / lbf ²	4.22 / 100.1	

Lubrication system

Lubricating oil consumption at			
Prime Power	liter/h / US gal/h	0.12 / 0.032	0.16 / 0.042
Maximum Standby Power	liter/h / US gal/h	0.13 / 0.034	0.18 / 0.048
Oil system capacity including filters	liters	64	
Oil change interval			
CD oil quality	h	200	
VDS oil quality	h	400	

Fuel system

Specific fuel consumption at			
25% of Prime Power	g/kWh / lb/hph	230 / 0.373	240 / 0.389
50% of Prime Power	g/kWh / lb/hph	210 / 0.340	214 / 0.347
75% of Prime Power	g/kWh / lb/hph	205 / 0.332	208 / 0.337
100% of Prime Power	g/kWh / lb/hph	209 / 0.339	212 / 0.344
Specific fuel consumption at			
25% of Maximum Standby Power	g/kWh / lb/hph	227 / 0.368	236 / 0.383
50% of Maximum Standby Power	g/kWh / lb/hph	208 / 0.337	212 / 0.344
75% of Maximum Standby Power	g/kWh / lb/hph	205 / 0.332	208 / 0.337
100% of Maximum Standby Power	g/kWh / lb/hph	213 / 0.345	217 / 0.352

Intake and exhaust system

Air consumption at			
Prime Power (at 25 °C)	m ³ /min / cfm	31.8 / 1123	39.3 / 1388
Maximum Standby Power (at 25 °C)	m ³ /min / cfm	34.9 / 1211	41.8 / 1476
Max allowable air intake restriction	kPa / In wc	5 / 20.1	5 / 20.1
Heat rejection to exhaust at			
Prime Power	kW / BTU/min	369 / 20984	415 / 23600
Maximum Standby Power	kW / BTU/min	416 / 23657	482 / 27410
Exhaust gas temperature after turbine at			
Prime Power	°C / °F	550 / 1015	520 / 965
Maximum Standby Power	°C / °F	565 / 1045	560 / 1035
Max allowable back-pressure in exhaust line	kPa / In wc	5.0 / 20.1	7.0 / 28.1
Exhaust gas flow at			
Prime Power	m ³ /min / cfm	90.3 / 3189	105 / 3708
Maximum Standby Power	m ³ /min / cfm	99 / 3496	116.6 / 4117

Cooling system

Heat rejection radiation from engine at			
Prime Power	kW / BTU/min	26 / 1478	30 / 1706
Maximum Standby Power	kW / BTU/min	29 / 1649	33 / 1877
Heat rejection to coolant at			
Prime Power	kW / BTU/min	180 / 10236	211 / 11999
Maximum Standby Power	kW / BTU/min	195 / 11089	235 / 13364
Fan power consumption	kW / hp	12 / 16	21 / 29

Power Standards

The engine performance corresponds to ISO 3046, BS 5514 and DIN 6271. The technical data applies to an engine without cooling fan and operating on a fuel with calorific value of 42.7 MJ/kg (18360 BTU/lb) and a density of 0.84 kg/litre (7.01 lb/US gal, 8.42 lb/Imp gal), also where this involves a deviation from the standards. Power output guaranteed within 0 to +2 % at rated ambient conditions at delivery. Ratings are based on ISO 8528.

Engine speed governing in accordance with ISO 3046/IV, class A1, and ISO 8528-5 G2 (G3 with electronic speed governor).

Exhaust emissions

The engine exhaust emissions complies with EPA, CARB and TA-luft regulations.

Rating Guidelines

PRIME POWER rating corresponds to ISO Standard Power for continuous operation. It is applicable for supplying electrical power at variable load for an unlimited number of hours instead of commercially purchased power. A10 % overload capability is available for this rating.

CONTINUOUS STANDBY POWER rating corresponds to ISO Power. It is applicable for supplying standby electrical power at variable load for an unlimited number of hours in the event of normal utility power failure. A 10 % overload capability is available for this rating.

MAXIMUM STANDBY POWER rating corresponds to ISO Standard Fuel Stop Power. It is applicable for supplying standby electrical power at variable load in areas with well established electrical networks in the event of normal utility power failure. No overload capability is available for this rating.